

J3 VIBRATING WIRE TRIAXIAL JOINTMETER

Datasheet J3

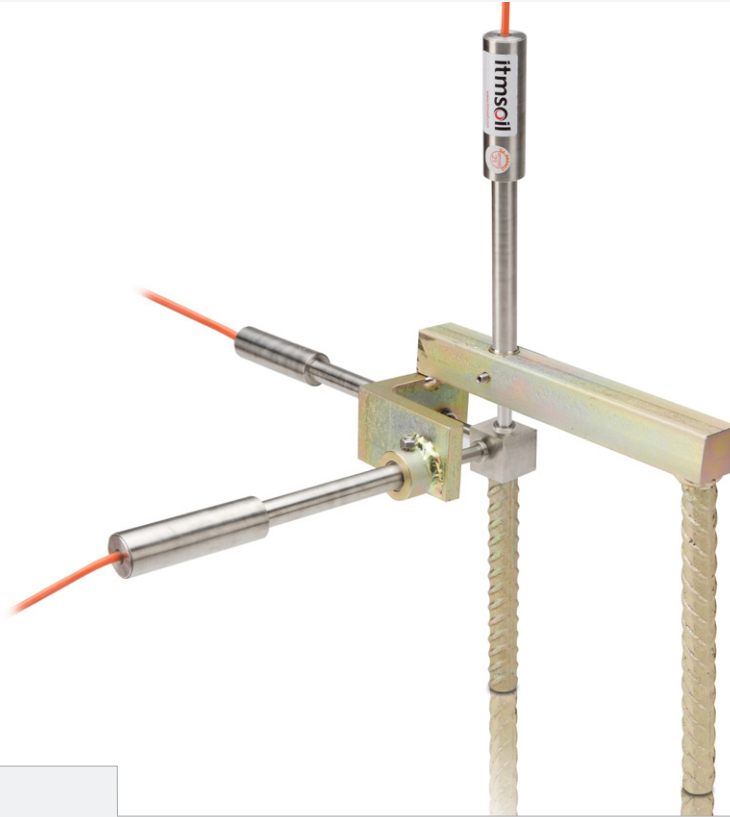

Description

The Vibrating Wire Triaxial Jointmeter is designed to monitor three way displacement at joints and cracks. The reference anvil design allows the Vibrating Wire transducers to show independent movement in all directions, irrespective of each other.

The Jointmeter comprises a 3D mounting system which consists of 2 arms and 2 groutable anchors. Three Vibrating Wire displacement transducers, which also monitor temperature, are installed within the mounting system and positioned for monitoring.

Data is retrieved either remotely or manually; a datalogger is used for remote monitoring and a handheld datalogger/readout unit for manual reading.

The Vibrating Wire Triaxial Jointmeter is easy to install, requiring minor drilling into the concrete slab and is particularly suited for use on concrete faced dams.

Features

- Reads in X, Y and Z axes
- Uses proven Vibrating Wire technology
- Proven in long-term monitoring
- Suitable for manual or remote monitoring
- Fully waterproof
- Fitted with thermistor for temperature monitoring
- Accurate and robust

Benefits

- Three way independent movement monitoring in one easy installation
- Accurate, repeatable readings over long cable lengths
- Long working life, long-term stability and reliability
- Over-voltage surge arrestor fitted to protect against electrical damage
- Connecting cable is strong, screened and flexible



Comprehensive information about this product and our full range is available at www.itmsoil.com
If you would like to speak with someone directly please call +44 (0)1825 765044 or email sales@itmsoil.com

VIBRATING WIRE PRINCIPLE



A high carbon steel wire is held in tension between a fixed point and a movable point within the sensor.

The physical changes measured by the sensor result in small changes to the position of the movable point which results in a change to the tension of the wire.

The wire may be excited by either plucking or sweeping via a coil adjacent to the wire. The resulting resonant frequency (which is relative to the tension of the wire) is then recorded by the same coil. The reading can be displayed by instrument readout or recorded by data logging equipment.

Operation

The groutable anchors are installed either side of a joint or crack; the installation jig provided ensures that the two anchors are positioned correctly. Once the anchors are set in position the installation jig is removed and the VW transducers are installed. The VW transducers are positioned against the reference anvil face, most commonly set to their mid-point, and the cables wired up.

Movement in the monitored position will result in relative change between the two anchors; this in turn will cause one or more of the VW transducer rods to move independently, changing the frequency of the wire. This change in frequency is recorded and can be converted to show the movement in millimetres.

Typically signal cables run from the sensors to a datalogger for remote reading. Alternatively, a terminal/junction box is used and a handheld readout or datalogger is used to manually record the readings.

An initial datum reading is taken and this can then be compared to all subsequent readings to give the change and magnitude of displacement.

Applications

Vibrating Wire Triaxial Jointmeters are used for monitoring of movements at construction joints; typical examples include:

- Concrete dams
- Tunnels
- Tanks
- Masonry structures

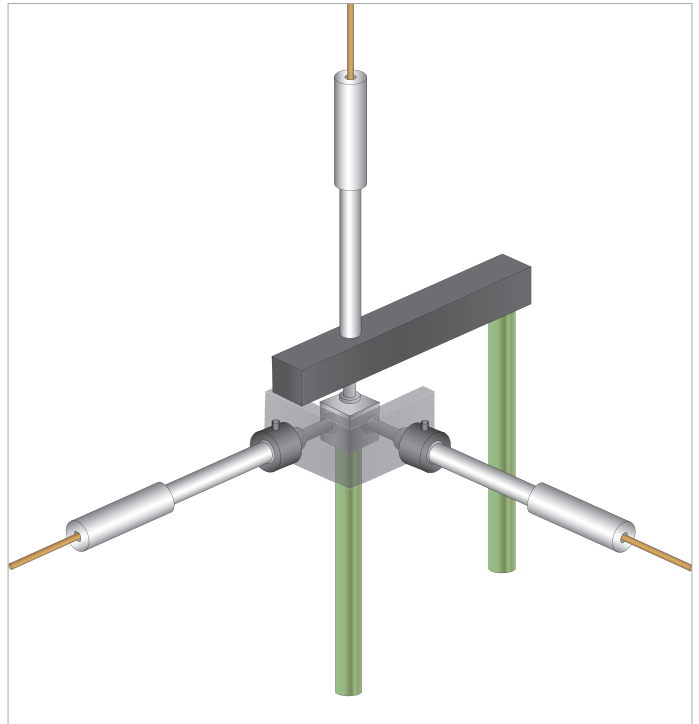

Associated products

For details on:	Catalogue code:
Terminal and Junction Boxes	RO-TB/JB/TJ
Dataloggers	D1
VW Crackmeter	J2

View our full product range on www.itmsoil.com

THE TECHNICAL RATING FOR THIS PRODUCT:

As the correct installation of any monitoring sensor or system is vital to maximise performance and accuracy, itmsoil makes the following recommendations, for the skill level of the installation contractor.

ADDITIONAL SUPPORT

itmsoil offer installation and monitoring services to support this system. For more information please email : sales@itmsoil.com or call **+44 (0) 1825 765044**

BASIC

ADVANCED

INTERMEDIATE

BASIC

The installer is trained and experienced in the installation of this type of instrument or systems, and is ideally a specialist Instrumentation and Monitoring contractor.

The installer already has previous experience and/or training in the installation of this instrument or system.

As a minimum the installer has read and fully comprehends the manual, and if possible has observed these instruments or systems being installed by others.

Specifications

Vibrating Wire Transducer

Range	30mm
Resolution ¹	0.025% full scale
Accuracy	±0.2mm% full scale
Temperature range	-20 to +80°C
Weight less cable	190g
Dimensions ²	290mm x Ø19mm
Excitation method	Pluck or sweep
Material	316 grade Stainless Steel
Ingress protection	IP68 to 1700kPa

Cable

Type	Standard
Construction	4 Core, PUR sheath, foil screen & drain wire
Diameter	4mm
Weight/m	30g
Maximum recommended cable length	mV/V - 40 metres 4-20mA - 1000 metres

Thermistor

Type	NTC 3k Ω
Accuracy	±0.5°C
Resolution ¹	0.1°C

Anchors

Type	Groutable
Material ³	Zinc plated steel
Dimensions	165mm x Ø20mm and 214mm x Ø20mm

3D Mounting

Material	Zinc plated steel
Dimensions	260mm x 112mm x 112mm

Reference Anvil (part of 3D mounting)

Material	Stainless Steel
Dimensions	31mm x 31mm x 31mm

¹ Dependent on readout

² In the closed position

³ Available in Stainless Steel

Ordering Information

Vibrating Wire Triaxial Jointmeters

Armoured cable can only be fitted on site with joint sealing kit CA-4.1

J3-1.15	Vibrating wire triaxial jointmeter; 30mm range, includes 3No. VW displacement transducers, mounted on arms with anchors and thermistor Sealed to 15 Bar
J3-1.15-C	Protective cover; for J3-1.15 Triaxial Jointmeter

Connecting Cable and Fittings

CA-3.1-4-IC	Instrument cable, 4 core, 7/0.20; screened, priced per metre, polyurethane jacket
CA-2.2-12-SC	12 core, multicore cable, 7/0.20; screened, priced per metre, PVC jacket
RO-JB-TJM	Junction box; for 3No. VW Displacement Transducers into 12 core multicore cable
CA-4.1	Joint sealing kit
CA-4.2	Coloured adhesive tapes; set of 10No.
CA-4.3	Crimping tool
CA-4.4	Crimping sleeves; set of 100No.
W6-6.1	Nylon ties; priced each, 150mm x 3.5mm, pack of 100No.
ST1-3.5	Nylon ties; priced each, 370mm x 4.7mm, pack of 100No.

Installation Equipment

W6-4.4	Polyester resin cartridge; 150ml, to fix anchor into drill hole
W6-4.5	Cartridge injection tool

Manual

MAN-147	Vibrating Wire Triaxial Jointmeter
---------	------------------------------------

soil
INSTRUMENTS



FM 553710 EMS 565522 OHS 565523

Bell Lane, Uckfield, East Sussex
TN22 1QL United Kingdom

t: +44 (0) 1825 765044
f: +44 (0) 1825 744398

e: info@itmsoil.com
w: www.itmsoil.com

Soil Instruments Ltd. Registered in England. Number: 07960087. Registered Office: 5th Floor, 24 Old Bond Street, London, W1S 4AW